

# Panasonic®

DTV Compatible  
Projection Monitor-Receiver  
Operating Instructions

PT-56WXF95

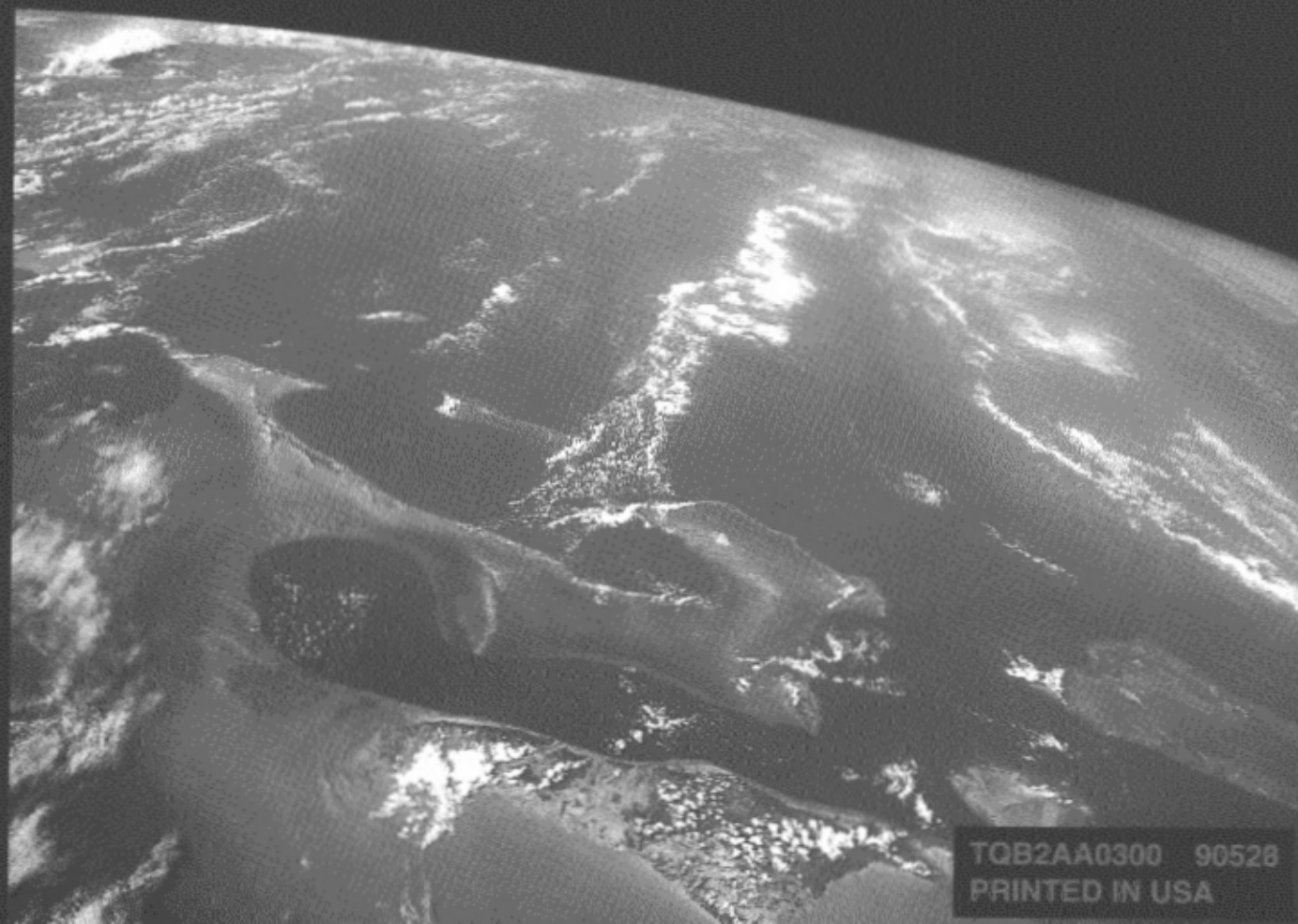

TQB2AA0300 90528  
PRINTED IN USA

## WARNING

To move set, push from left side of set. Casters on right side do not pivot in all directions. Set can tip over if moved from right side, with risk of personal injury.

## ADVERTENCIA

Para mover el conjunto, empuje desde el lado izquierdo del mismo. Los rolanas de la derecha no son pivotantes en todas las direcciones. El conjunto se puede tumbar si se lo mueve desde el lado derecho, corriendo así el riesgo de sufrir daños personales.

## Mise en garde

Lors du déplacement du téléviseur, le pousser sur son côté gauche. Les roulettes du côté droit ne pouvant tourner dans toutes les directions, l'appareil pourrait tomber s'il est poussé de ce côté et causer ainsi des risques de blessure.

## 警告

移動本機時，請從本機左側推動。推車右側不能旋轉。如從右側移動，則機體可能傾倒並造成傷害。

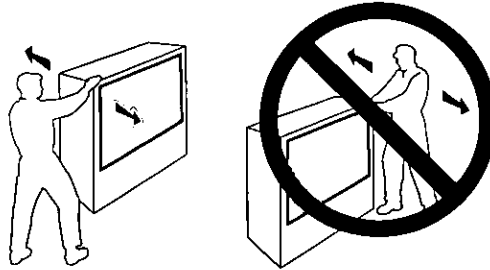

The lightning flash with arrow head within a triangle is intended to tell the user that parts inside the product are a risk of electric shock to persons.



The exclamation point within a triangle is intended to tell the user that important operating and servicing instructions are in the papers with the appliance.

**WARNING:** To prevent fire or shock hazard, do not expose this appliance to rain or moisture.

Certain audio features of this product are manufactured under a license from Desper Products, Inc. Spatializer® and the circle-in-square device and trademarks owned by Desper Products, Inc. Spatializer U.S. Patents are: 4,308,423; 4,355,203 and 5,412,731.

Panasonic Consumer Electronics Company,  
Division of Matsushita  
Electric Corporation of America  
One Panasonic Way  
Secaucus, New Jersey 07094  
www.panasonic.com  
(800) 222-4213

**Table of Contents**

<b>Congratulations .....</b>	<b>2</b>
Customer Record .....	2
Care and Cleaning .....	2
Specifications .....	2
<b>Installation .....</b>	<b>3</b>
Television Location .....	3
Optional Cable Connections .....	3
AC Power Supply Cord .....	3
Cable / Antenna Connections .....	3
<b>Optional Equipment Connections .....</b>	<b>4</b>
VCR Connection .....	4
Front A/V Input Jacks .....	5
Cable Box Connection .....	5
VCR and Cable Box Connection .....	6
Amplifier Connection (To Audio Amp) .....	7
Program Out Connection (PROG. OUT) .....	7
<b>Home Theater Connection .....</b>	<b>8</b>
<b>Split Screen Operation .....</b>	<b>9</b>
Without a VCR / With a VCR and Cable Box .....	9
With a VCR -No Cable Box .....	9
<b>Roller Guide Menu .....</b>	<b>10</b>
Basic Navigation .....	10
Remote Control Guide .....	10
<b>Roller Guide Menu Chart .....</b>	<b>11</b>
<b>Special Features .....</b>	<b>14</b>
Menu Languages .....	14
Program Channels .....	14
Closed Caption .....	15
Convergence .....	16
Sleep Timer .....	17
Program Timer 1 and 2 .....	17
Picture Adjustments .....	18
Audio Adjustments .....	18
Favorite Channels and Captions .....	19
Lock .....	20
<b>Digital TV Set-Top Box (DTV-STB) Connection ...</b>	<b>21</b>
<b>Glossary .....</b>	<b>22</b>
<b>Frequently Asked Questions About Digital TV ....</b>	<b>23</b>
<b>Troubleshooting Chart .....</b>	<b>24</b>

**Read these instructions completely before operating TV.**

**Contents are subject to change without notice or obligation.**

Copyright 1999 by Matsushita Electric Corporation of America. All rights reserved.

Unauthorized copying and distribution is a violation of law.

## CONGRATULATIONS

### Congratulations

Your new Projection Television (PTV) features state-of-the-art technology for high-quality picture and sound with complete audio/video connections for your home theater system. Standard television signals are displayed in a progressive scan format, providing a clear, crisp picture without visible scan lines. This PTV is also DTV (Digital TV)-compatible. When connected to a Panasonic digital TV set-top box, this TV can display high-definition (HDTV) 1080i and 720p formats and standard definition (SDTV) 480p and 480i formats. Your new PTV is designed to give you many years of enjoyment. It was thoroughly tuned and tested at the factory for best performance.

### Customer Record

The model and serial number of this product are located on the back of the TV. You should note the model and serial number in the space provided and retain as a permanent record of your purchase. This will aid in identification in the event of theft or loss. Product registration is available at: [www.prodreg.com/panasonic](http://www.prodreg.com/panasonic).

Model  
Number  
Serial  
Number

### Care and Cleaning

#### Protective Screen (Turn PTV Off)

The projection screen is a precision lens system and has a protective screen. The protective screen is fully washable with the following precautions:

- Use a mild soap solution or window cleaner and a clean cloth.
  - DO NOT USE ABRASIVE CLEANERS.
  - Do not use laundry detergent or automatic dishwasher soap.
  - Do not use alcohol, ammonia, or petroleum based products.
- Avoid excessive moisture and wipe dry.
  - Prevent solution from running into the receiver below.
- Avoid bumping or scraping the screen.

#### Cabinet and Remote Control

- For cabinets and Remote Control, use a soft cloth dampened with water or a mild detergent solution. Avoid excessive moisture and wipe dry.
- Do not use benzene, thinner or other petroleum based products.

### Specifications

<b>Power Source</b> PT-56WXF95	120V AC, 60Hz
<b>Channel Capability - 181</b>	VHF-12; UHF-56; Cable-125
<b>3 Video Input Jacks</b>	1Vp-p, 75 Ohm, Phono Jack Type
<b>6 Audio Input Jacks</b>	500mV RMS 47K Ohm
<b>Video Output Jack</b>	1Vp-p, 75 Ohm, Phono Jack Type
<b>2 Audio Output Jacks</b>	0-2.0V RMS 4.7K Ohm
<b>4 S-Video Jacks (3 inputs &amp; 1 output)</b>	S-Video (Y-C) Connector
<b>2 Component Video Inputs (Y, P<sub>B</sub>, P<sub>R</sub>)</b>	75 Ohm, Phono Jack Type

Specifications are subject to change without notice or obligation.

# Installation

## Television Location

This unit can be used as part of an entertainment center. Consult your dealer for available options.

- Avoid excessive sunlight or bright lights, including reflections.
- Keep away from excessive heat or moisture. Inadequate ventilation may cause internal component failure.
- Fluorescent lighting may reduce Remote Control transmitting range.
- Keep away from magnetic equipment, including motors, fans, or external speakers.

## Optional Cable Connections

Shielded audio and video cables should be used between components. For best results:

- Use 75-ohm coaxial shielded cables.
- Use appropriate input and output connectors, that match your component connectors.
- Avoid long cables to minimize interference.

## AC Power Supply Cord

**CAUTION:** TO PREVENT ELECTRIC SHOCK, MATCH WIDE BLADE OF PLUG TO WIDE SLOT OF AC OUTLET AND FULLY INSERT. DO NOT USE A PLUG WITH A RECEPTACLE OR OTHER OUTLET UNLESS THE BLADE CAN BE FULLY INSERTED TO PREVENT BLADE EXPOSURE.

**Polarized Plug**



## Cable / Antenna Connections

For proper reception, either a cable or antenna connection is required.

### Cable Connection

Connect the cable supplied by your local cable company to ANT1 connection on back of television. Select cable mode and ANT1 in SET UP menu under Prog Chan (Program Channels).

**Note:** A cable converter box may be required for proper reception. Check with your local cable company for compatibility requirements.

**Incoming Cable from Cable Company**

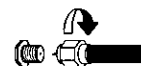



**75 Ohm VHF/UHF on back of TV**

### Antenna Connection

- For proper reception of VHF/UHF channels, an external antenna is required. For best reception, an outdoor antenna is recommended.
- Connect home antenna to back of television. Select TV mode and ANT1 in the SET UP Menu under Prog Chan.

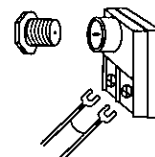
**Incoming Cable from Home Antenna**



 <b>Cable Preset</b>
Cable Mode is preset at the factory. Antenna users must change to TV Mode and ANT1 in the Set Up Menu under Prog Chan.



## Optional Equipment Connections (Cont.)

### Front A/V Input Jacks

Open the door on the TV front panel to use the connections for your optional equipment. Press the **TV/VIDEO** button to select VIDEO 3 input mode.

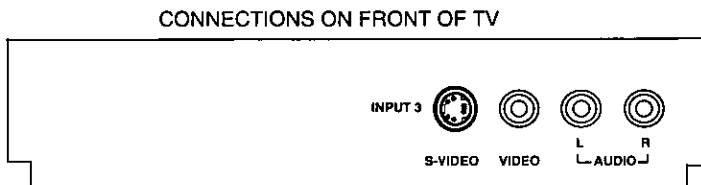

**Note:** A second VCR, a video disc player, video game equipment and DSS equipment can also be connected to the video inputs. See the optional equipment manual for details.

### Cable Box Connection

Follow this diagram when connecting your television to a cable box only.

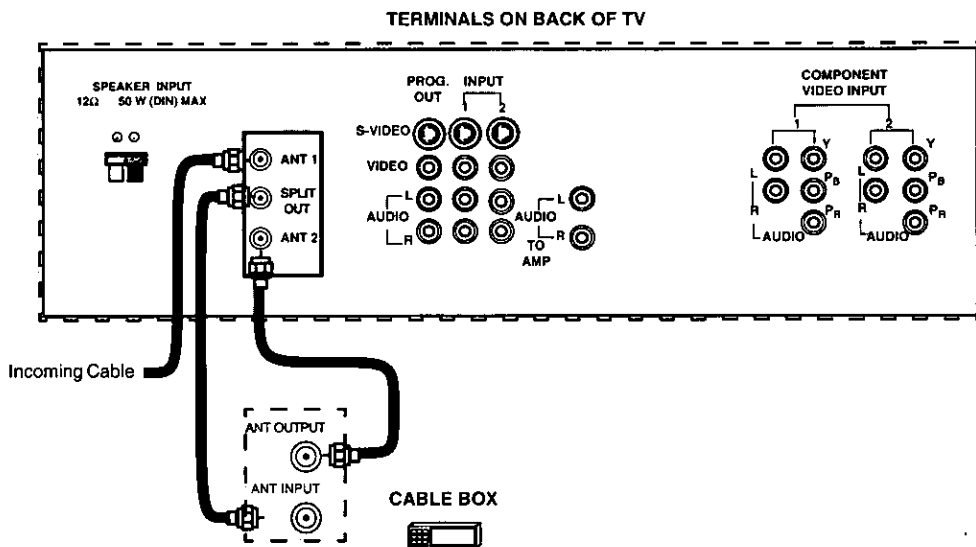

**Note:** The remote control must be programmed with supplied codes to operate the cable box. See *Programming the Remote Control* in the **Remote Control Quick Reference Guide**.

### Viewing a premium (scrambled) cable channel

#### Procedure

1. Select ANT2 in the SET UP menu under Prog Chan (Program Channels).
2. Tune the television to Channel 3.
3. Using the cable box, tune to the premium (scrambled) cable channel you want to view.

**Note:** To use special features such as Favorite Channels and Channel Captions (see *Special Features* section for more information), ANT1 must be selected in the SET UP menu under Prog Chan (Program Channels).

## Optional Equipment Connections (Cont.)

### VCR and Cable Box Connection

Follow this diagram when connecting your television to both a VCR and a cable box.

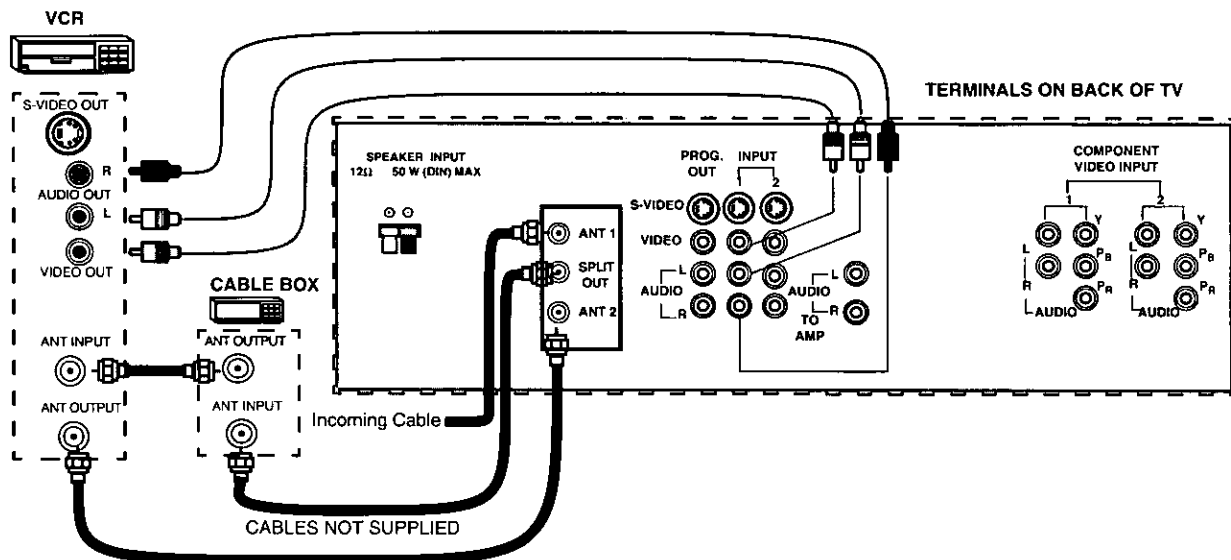

**Note:** The remote control must be programmed with supplied codes to operate the VCR and cable box. See Programming the Remote Control in the **Remote Control Quick Reference Guide**.

### Viewing a premium (scrambled) cable channel

#### Procedure

1. Select ANT2 in the SET UP menu under Prog Chan (Program Channels).
2. Tune the television to Channel 3.
3. Using the cable box, tune to the premium (scrambled) cable channel you want to view.

**Note:** To use special features such as Favorite Channels and Channel Captions (see Special Features section for more information), ANT1 must be selected in the SET UP menu under Prog Chan (Program Channels).

### Recording a premium (scrambled) cable channel

#### Procedure

1. Select ANT2 in the SET UP menu under Prog Chan (Program Channels).
2. Press the **TV/VIDEO** button on the remote control to select the input ( VIDEO 1, VIDEO 2, etc.) connected to your VCR.
3. Turn the VCR ON.
4. Tune the VCR to Channel 3 or 4, depending on your VCR.
5. Using your cable box, tune to the premium (scrambled) cable channel you want to record.
6. Begin recording.

**Note:** To view a different channel while recording:

- Select ANT1 in the SET UP menu under Prog Chan (Program Channel).
- Press the **TV/VIDEO** button on the remote control to select TV mode.
- Tune the television to a television program (except another premium (scrambled) cable channel).



## Optional Equipment Connections (Cont.)

### Amplifier Connection (TO AUDIO AMP)

Connect to an external audio amplifier input for listening through a stereo system.

**Note:** TO AUDIO AMP terminals cannot be connected directly to external speakers.

### Audio Adjustments

1. Select SPEAKERS ON located in the onscreen AUDIO menu.
2. Set amplifier volume to minimum.
3. Adjust TV volume to desired level.
4. Adjust amplifier volume to match the TV.
5. Select SPEAKERS OFF & VARIABLE AUDIO OUT from AUDIO menu.
6. Volume, mute, bass, treble and balance are now controlled through the television.

**Note:** Select SPEAKERS OFF & Fixed Audio Out to control audio functions through the external amplifier.

### Program Out Connection (PROG. OUT)

For monitoring the television audio and video with optional video equipment, connect to PROG. OUT terminals on the back of the TV.

### Procedure

1. Connect optional video equipment to PROG. OUT video and TO AUDIO AMP R/L Audio terminals.
2. PROG OUT terminal display is the same as the onscreen display.
3. See optional equipment manual for further instructions for recording or monitoring.

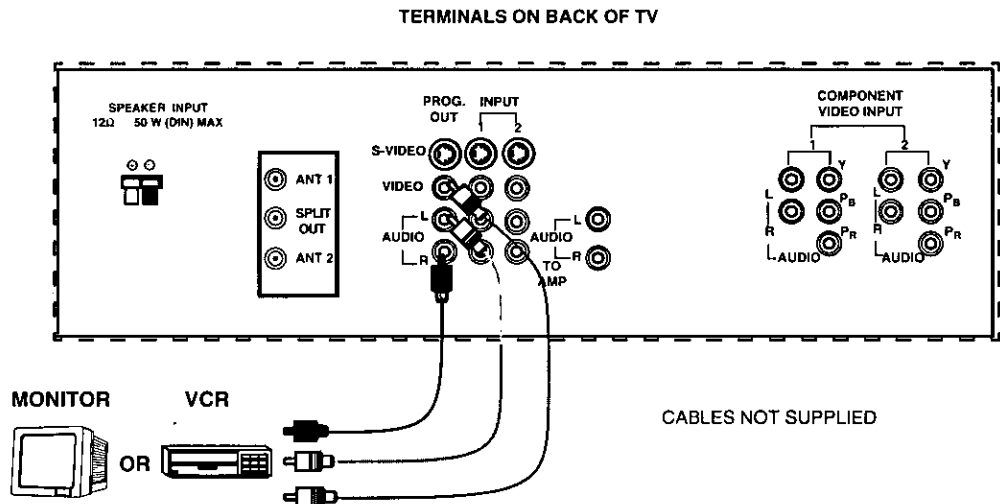

## Home Theater Connection

Your TV can be configured to use the TV speakers as center channel speakers in Dolby® surround sound transmission. Connect a Dolby surround sound amplifier to CENTER CHANNEL INPUT on the back of the TV, as shown. EXT & FIXED AUDIO OUT must be selected in the AUDIO Roller Guide™\*\* Menu under SPEAKERS.

\*\*U.S. Patent Pending

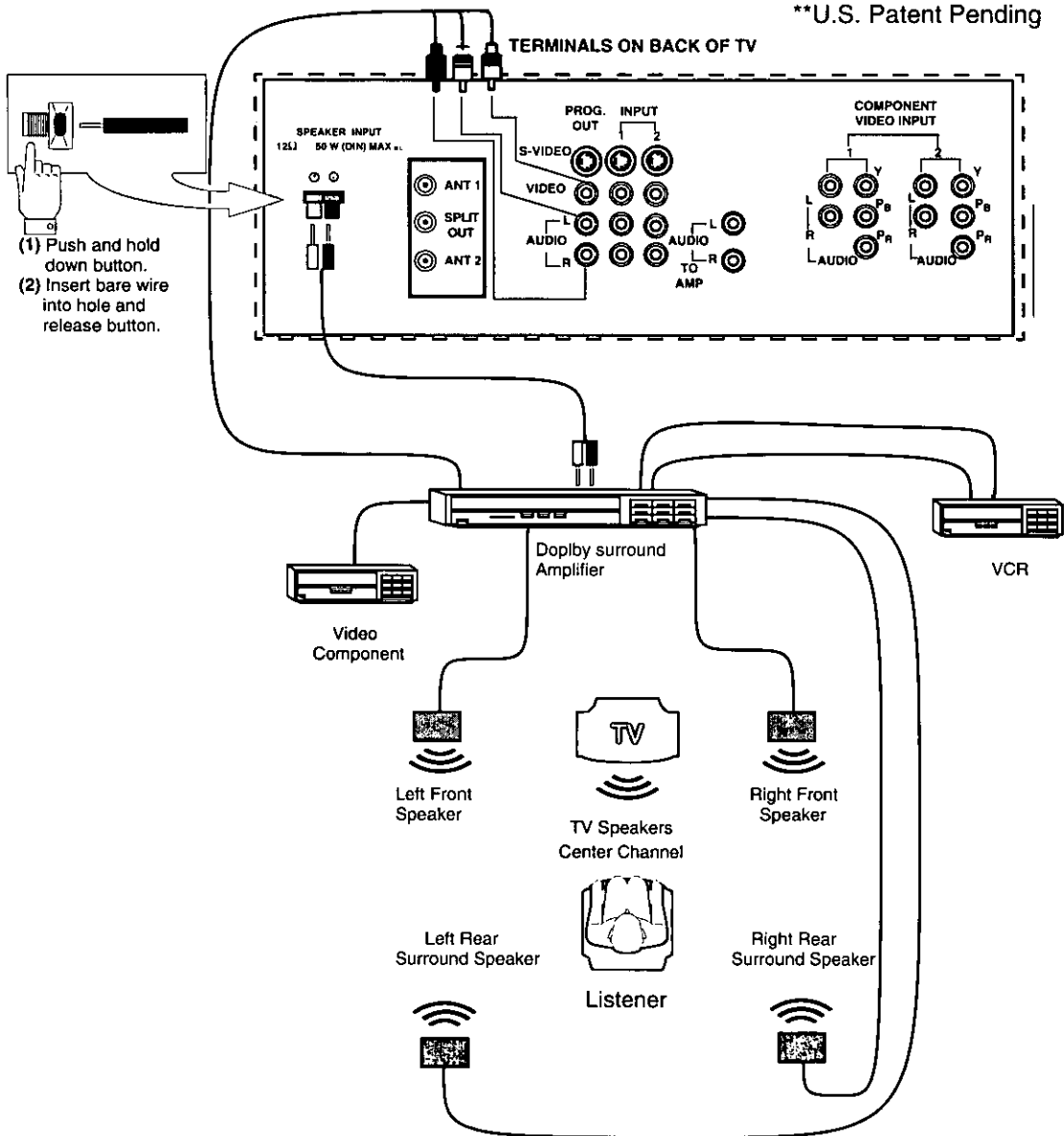

\*Manufactured under license from Dolby Laboratories. "Dolby", "AC-3", "Pro Logic" and the double-D symbol are trademarks of Dolby Laboratories.

## Split Screen Operation

This television includes a two tuner split screen feature. This allows watching two (2) live broadcasts at the same time with or without an external video source (VCR).

**Note:** *The Remote Control must be programmed with supplied codes to operate the VCR and Cable Box. See Programming the Remote Control in the **Remote Control Quick Reference Guide**.*

### Without a VCR

#### Procedure

- Connect incoming cable to antenna (ANT 1) input on back of TV.
- Press the **SPLIT**  button on the Remote Control to display the Split Screen.

**Note:** *The audio is for the Main Picture, only.*

- Choose channels for the *Split Screen Picture* by pressing the Remote Control **SPLIT CHANNEL** up/down buttons.
- Choose channels for the *Main Picture* by pressing the Remote Control **CH** up/down buttons or by using the numeric keypad.

### With a VCR and Cable Box

#### Procedure

Press the **SPLIT**  button on the Remote Control to display the Split Screen.

**Note:** *The audio is for the Main Picture only.*

To view scrambled channels through your Cable Box on the Split Screen:

- Verify the Cable Box and VCR are ON and the VCR tuned to Channel 3 or 4, depending on the VCR.
- Press the **TV/VIDEO** button on the Remote Control to select the video input for your VCR.
- Press **CBL** button on the Remote Control to select cable box.
- Choose channels for the *Split Screen* by pressing the **SPLIT CHANNEL** up/down buttons on the Remote Control or by using the numeric keypad.
- Choose channels for the *Main Picture* by pressing the **TV** button on the Remote Control and using the numeric keypad or **CH** up/down buttons.

### With a VCR- No Cable Box

#### Procedure

Press the **SPLIT**  button on the Remote Control to display the Split Screen.

**Note:** *The audio is for the Main Picture, only.*

To view an external video source in the Split Screen:

- Press the **TV/VIDEO** button on the Remote Control to select the video input for your VCR.
- Verify the VCR is on.
- Insert a tape into the VCR and push Play button to watch the video in the *Split Screen*.
- Choose channels for the *Main Picture* by pressing the **TV** button on the Remote Control and using the numeric keypad or **CH** up/down button.

**Note:** *The **SWAP** button switches the Split Screen and Main Picture source. Press the **RECALL** button for Split Screen status, onscreen.*

**Panasonic**

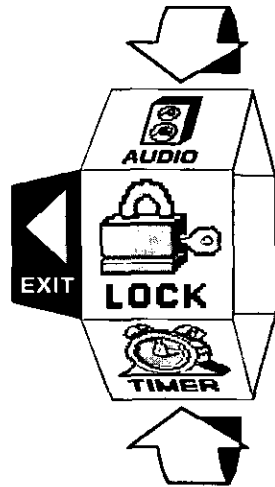

**ROLLER GUIDE MENU™ SELECTIONS**

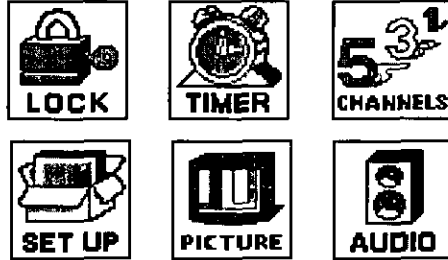

**▲▼ FOR MORE FEATURES  
PRESS ACTION TO SELECT**

**Basic Navigation**

**Procedure**

- ❑ Press the **ACTION** button in the middle of the large blue button on the remote control to display the Roller Guide Menu™.

**Note:** *Be careful to press the **ACTION** button in the middle of the button. If you do not press in the middle of the button, the channel or volume keys may be activated.*

- ❑ Press the **CH** up/down buttons to rotate the Roller Guide.
- ❑ Press the left **VOL** button to exit the Roller Guide Menu™.

**Navigation in the Roller Guide**

**Procedure**

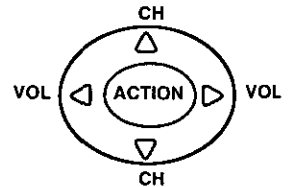

- ❑ Press the **ACTION** button to select main menu items.
- ❑ Press the **CH** up/down buttons to highlight submenus.
- ❑ Press the **VOL** buttons to select and adjust features.
- ❑ Press the **ACTION** button to return to submenus.





**Remote Control Guide**

The **Remote Control Quick Reference Guide** is located within the package provided with this TV.



**Roller Guide Menu Chart**

<b>MENU</b>	<b>DESCRIPTION</b>
	<b>SET UP</b>
<b>LANGUAGES</b>	<input type="checkbox"/> Select English, Spanish, or French menu.
<b>PROG. CHAN</b> (Program Channels)	<input type="checkbox"/> MODE - Select Cable or TV (Antenna). See Installation section in Manual. <input type="checkbox"/> ANTENNA - Select ANT 1 or ANT 2. See Installation section in manual. <input type="checkbox"/> AUTO PROGRAM - Automatically program channels having a signal into memory. <input type="checkbox"/> MANUAL PROGRAM - Manually add or delete channels from memory.
 (Closed Captioned)	<input type="checkbox"/> CC ON MUTE - Select C1-C4 for Closed Captioning display when the Remote MUTE button is pressed. <input type="checkbox"/> CC MODE - Select T1-T4 or C1-C4 for transmitted information, if available, in large black box.
<b>OTHER ADJ.</b>	<input type="checkbox"/> CONVERGENCE - Adjustment may be required when the PTV is moved because of the effects of the Earth's magnetic field on the projection tubes.
	<b>AUDIO</b>
<b>AUDIO ADJ.</b> (Adjustments)	<input type="checkbox"/> MODE - Select STEREO, SAP (Second Audio Program) or MONO. (Use MONO when stereo signal is weak.) <input type="checkbox"/> BASS - Increase or decrease the bass response. <input type="checkbox"/> TREBLE - Increase or decrease the treble response. <input type="checkbox"/> BALANCE - Emphasize the left/right speaker volume. <input type="checkbox"/> NORMAL - Reset BASS, TREBLE and BALANCE to factory default.
<b>OTHER ADJ.</b> (Adjustments)	<input type="checkbox"/> AI SOUND - Equalize overall volume levels across all programs. (AI sound is not available in VIDEO mode).

**Roller Guide Menu Chart (Cont.)**

<i><b>MENU</b></i>	<i><b>DESCRIPTION</b></i>
<b>SURROUND</b>	<input type="checkbox"/> <b>SPATIALIZER®</b> - Three dimensional surround sound with two speakers.
<b>SPEAKERS</b>	<input type="checkbox"/> <b>AUDIO SOURCE</b> <ul style="list-style-type: none"> <li>• TV - speakers operate normally.</li> <li>• EXT &amp; VAO (Variable Audio Output) - TV speakers off - audio adjustable by TV.</li> <li>• EXT &amp; FAO (Fixed Audio Output)- TV speakers off — audio adjustable only by the external amplifier.</li> </ul>
	<b>TIMER</b>
<b>CLOCK SET</b>	<input type="checkbox"/> Set the time and the day of the week. (Time will display onscreen after turning the television on, pressing the RECALL button or changing channels).
<b>SLEEP</b>	<input type="checkbox"/> Set timer to turn off TV in 30, 60 or 90 minutes. Select NO to turn timer off.
<b>TIMER 1</b> <b>TIMER 2</b>	<input type="checkbox"/> Set one or both timers to automatically turn TV on and off at selected times, on selected channels, and on selected days. (Clock must be set to use Timer features.)
	<b>PICTURE</b>
<b>VIDEO ADJ..</b> (Adjustments)	<input type="checkbox"/> <b>COLOR</b> - Adjust desired color intensity. <input type="checkbox"/> <b>TINT</b> - Adjust natural flesh tones. <input type="checkbox"/> <b>BRIGHTNESS</b> - Adjust dark areas for crisp detail. <input type="checkbox"/> <b>PICTURE</b> - Adjust white areas of picture. <input type="checkbox"/> <b>SHARPNESS</b> - Adjust clarity of outline detail. <input type="checkbox"/> <b>NORMAL</b> - Reset all picture adjustments to factory default settings.

**Roller Guide Menu Chart (Cont.)**

<b>MENU</b>	<b>DESCRIPTION</b>
<p><b>OTHER ADJ.</b> (Adjustments)</p>	<ul style="list-style-type: none"> <li><input type="checkbox"/> COLOR TEMP - Adjust white balance to COOL (blue), WARM (red) or NORMAL.</li> <li><input type="checkbox"/> SCAN MODE - Picture adjustment when switching between video games and DTV picture, if needed.</li> <li><input type="checkbox"/> COLOR MATRIX - Select HD OR SD to automatically adjust color parameters for HD (high definition) and SD (standard definition) transmissions.</li> </ul>
	<p><b>CHANNELS</b></p>
<p><b>FAVORITES</b></p>	<ul style="list-style-type: none"> <li><input type="checkbox"/> CHANNEL SCAN - Select FAV (16 favorites) or ALL channels to scan channels using the up/down CH buttons.</li> </ul>
<p><b>CAPTION</b></p>	<ul style="list-style-type: none"> <li><input type="checkbox"/> PRESET CAPTION - Enter channel numbers for preset captions.</li> <li><input type="checkbox"/> MANUAL CAPTION - Enter channel numbers and captions manually.</li> <li><input type="checkbox"/> INPUT LABEL - Label video connections for onscreen display of optional equipment.</li> </ul>
	<p><b>LOCK</b></p>
<p><b>FAVORITES</b></p>	<ul style="list-style-type: none"> <li><input type="checkbox"/> Under Mode lock All, Channels or Game with a secret code.</li> </ul>
<p><b>HOW LONG?</b></p>	<ul style="list-style-type: none"> <li><input type="checkbox"/> Under HOW LONG select the period of time (12, 24, 48 hours or ALWAYS) for your option to be locked.</li> </ul>

**Special Features**

**SET UP**

**Menu Languages**

In SET UP Menu, select IDIOMA / LANGUE to change menu language to ENGLISH, ESPAÑOL (Spanish) or FRANÇAIS (French).

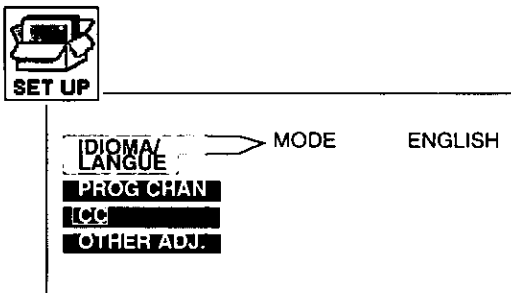

**Prog Chan (Program Channels)**

In SET UP menu under PROG.CHAN select:

- MODE to select TV (antenna) or CABLE mode depending on the signal source.
- ANTENNA to select either ANT1 or ANT2.
- AUTO PROGRAM to automatically program all channels with a signal.
- MANUAL PROGRAM to manually add or delete channels.

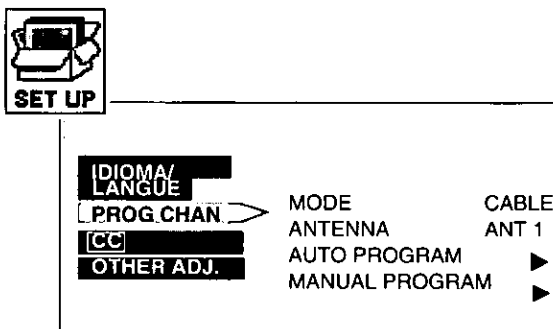



**CC (Closed Caption)**

This television contains a built-in decoder that displays **CC** (Closed Caption) text across the screen (white or colored letters on black background). It allows the viewer to read the dialogue of a television program or other information. The program viewed must include Closed Captioning for the feature to work.

**CC Mode**

- In SET UP Menu, select **CC** (Closed Caption).
- Select **CC** MODE.
- Select OFF, C1, C2, T1, T2, C3, C4, T3 or T4:
  - OFF - When Closed Caption is not desired.
  - C1 - For video related information to be displayed, up to 4 lines onscreen at a time. (It does not block relevant parts of the picture). Text may be in any language.
  - C2 to C4 - For other modes of video related information.
  - T1 - For program guide and other information to be displayed, when available. (Blocks a large portion of the picture on the television screen).
  - T2 to T4 - For other modes of information. (Blocks a large portion of the picture on the television screen).
- Press **ACTION** to return to submenu options, and exit menus.

**CC On Mute**

Activates the onscreen Closed Caption feature when the **MUTE** button on the remote control is pressed. To deactivate press the **MUTE** button again.

**Note:** This feature only functions when the Closed Caption Mode is OFF. The program being viewed must be broadcast with Closed Captioning. (Refer to your local TV guide).

- In SET UP Menu, select **CC** (Closed Caption).
- Select **CC** ON MUTE
- Select NO, C1, C2, C3, or C4.
- Recommended set up for Closed Caption when using the MUTE button:
  - **CC** ON MUTE: C1
  - **CC** MODE: OFF
- Press **ACTION** to return to submenu options, and exit menus.
- Press the **MUTE** button to activate the Closed Caption feature.
- Press the **MUTE** button again to deactivate the feature.

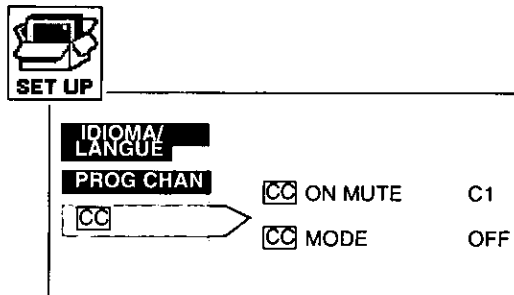

## Convergence

In SET UP menu, select CONVERGENCE under OTHER ADJ. only after moving the PTV to adjust for the effects of the earth's magnetic field on the projection tubes.

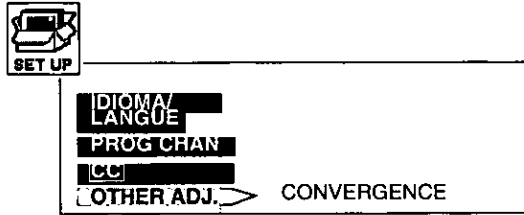

**Note:** Convergence seldom needs adjusting, except when moving the TV.

Use the navigation buttons to align the horizontal and vertical green lines on screen with the outside reference marks, as shown below. Press the **ACTION** button to move to the RED CONVERGENCE screen.

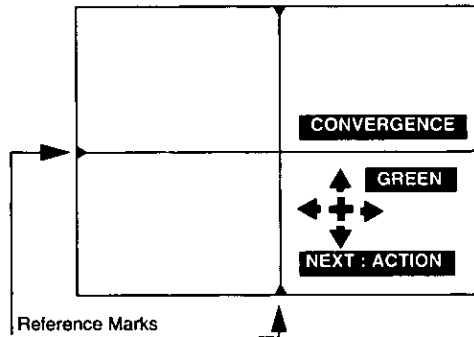

Use the navigation buttons to align the red cross with the white cross pattern at the center of the screen. Press **ACTION** to continue to the blue convergence adjustment screen and repeat.

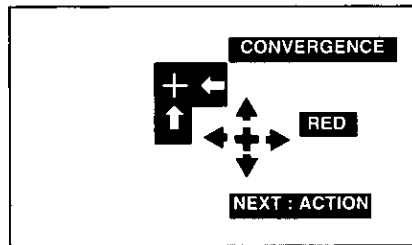

**Note:** TO PREVENT PICTURE TUBE DAMAGE, DO NOT LEAVE TEST PATTERN ON FOR AN EXTENDED PERIOD OF TIME.



### Convergence Adjustment

---

An adjusted cross pattern appears white with a minimum of color fringing.

**TIMER**

**Sleep**

In TIMER menu, select SLEEP to turn TV off in 30, 60 or 90 minutes. Select NO to turn off timer.

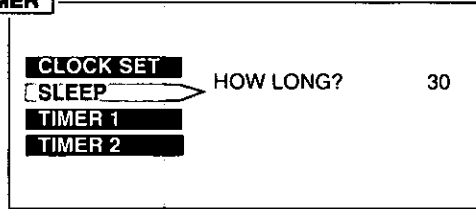

**Timer 1 and Timer 2**

In TIMER menu, select one or both timers to turn the television on and off at selected times, on selected channels, and on selected days.

**Note:** TIME must be entered in CLOCK SET to operate TIMER features.

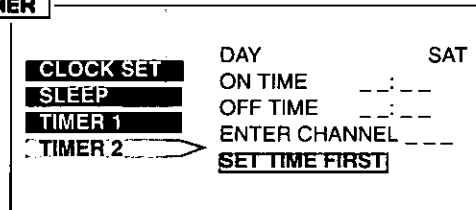

**Turn Off After 90 Minutes**

The TV automatically turns OFF after 90 minutes when turned on by the TIMER. If the OFF time is selected or if any key is pressed, the automatic OFF after 90 minutes will be cancelled.



**TIMER Activation**

The TIMER is active when the TV is OFF or ON. The TV will switch to the selected channel at the selected time set in the TIMER.

**PICTURE**

**Other Adjustments**

In PICTURE menu under OTHER ADJ., select:

- COLOR TEMP (temperature) to increase or decrease WARM (red) and COOL (blue) colors to suit personal preferences.
- SCAN MODE select TV or GAME to do picture adjustment when switching between video games and DTV picture, if needed.
- COLOR MATRIX select HD OR SD to automatically adjust color parameters for HD (high definition) and SD (standard definition) transmissions.

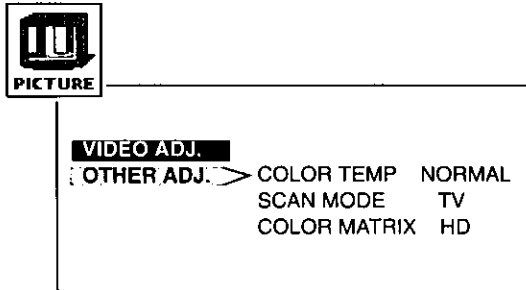

*Note:* COLOR MATRIX is only adjustable in DTV mode.

**AUDIO**

**Speakers**

In AUDIO menu under SPEAKERS, select:

- AUDIO SOURCE - TV for normal TV speakers.
- EXT & VAO (variable audio out) to adjust speakers from TV controls.
- EXT & FAO (fixed audio out) to adjust speakers from an external amplifier.

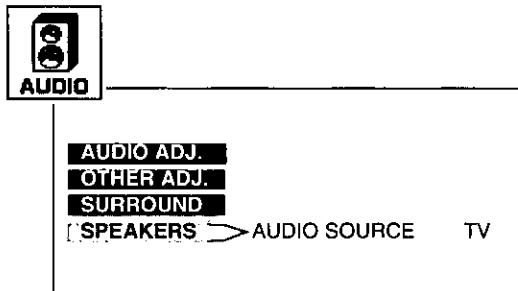

# CHANNELS

## Favorites

In CHANNELS menu under FAVORITES select:

- CHANNEL SCAN FAV to enter up to 16 favorite channels
- CHANNEL SCAN ALL to scan all channels when using the CH up/down buttons.

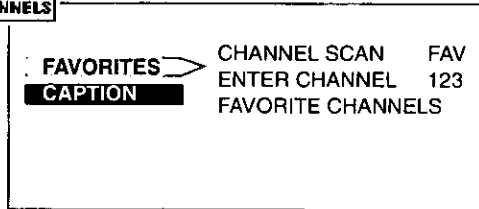

## Caption

In CHANNELS menu under CAPTION select:

- PRESET CAPTION to enter channel labels for popular TV stations.
- MANUAL CAPTION to enter numbers and captions manually.
- INPUT LABEL to label video input connections for onscreen display by source (VCR, DVD, etc.).

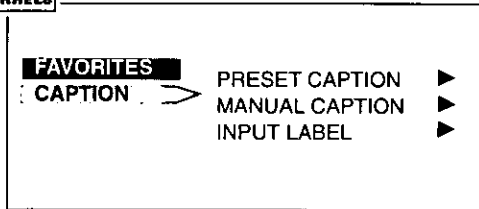

**LOCK**

**Mode**

To use LOCK options:

- ENTER CODE FIRST - Use the numeric keypad to enter a four-digit secret code. After entering your secret code for the first time, the onscreen display will change to CHANGE CODE.

**Note:** Use a code that is easy to remember or record it in a safe place.

In MODE submenu select:

- LOCK SET to choose:
  - OFF - To turn lock function off.
  - ALL - To lock all channels and video inputs.
  - CHANNEL - To lock up to four channels of your choice.
  - GAME - To lock channels 3, 4 and video inputs.
- MOTION PICT <sup>★</sup> - To use Motion Picture Ratings.
- TV PARENTAL <sup>★</sup> - To use TV Parental Guide Ratings.
- CHANGE CODE - Use numeric keypad to change your four-digit secret code.

**Note:** If in CHANGE CODE you enter a different code from the one used previously, the new code becomes the controlling code.

Press **ACTION** button to return to submenu, then select HOW LONG to choose the period of time you want your option to be locked (12, 24, 48 hours or ALWAYS).

**Note:** Be cautious when selecting ALWAYS. If ALWAYS is selected, and you forget your secret code, the television must be serviced by a qualified technician in order to clear the LOCK setup.

Press **ACTION** to return to submenu, and to exit menus.

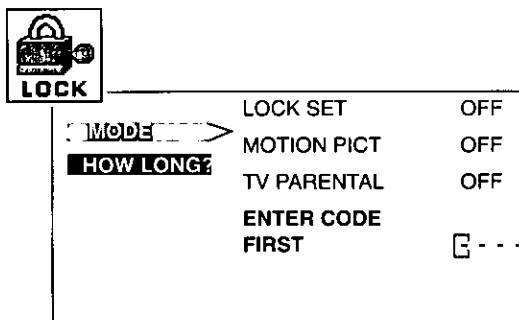

**Note:** If GAME, CHANNEL or ALL is selected, and if a blocked channel or video input is selected, the message PG (Parent Guard) displays in the upper right corner of the television screen

Unlock LOCK SET by reentering the same four-digit secret code and selecting OFF.

<sup>★</sup> For more information about Motion Picture Status and TV Parental Guide, see the V-CHIP Parental Lock manual provided with the TV package.

## Digital TV - Set-Top Box (DTV-STB) Connection

Use this diagram to connect the Panasonic DTV-STB (Digital TV-Set-Top Box) to the back of your TV.

DTV TERMINALS ON BACK OF TV

DTV TERMINALS ON BACK OF DTV-STB

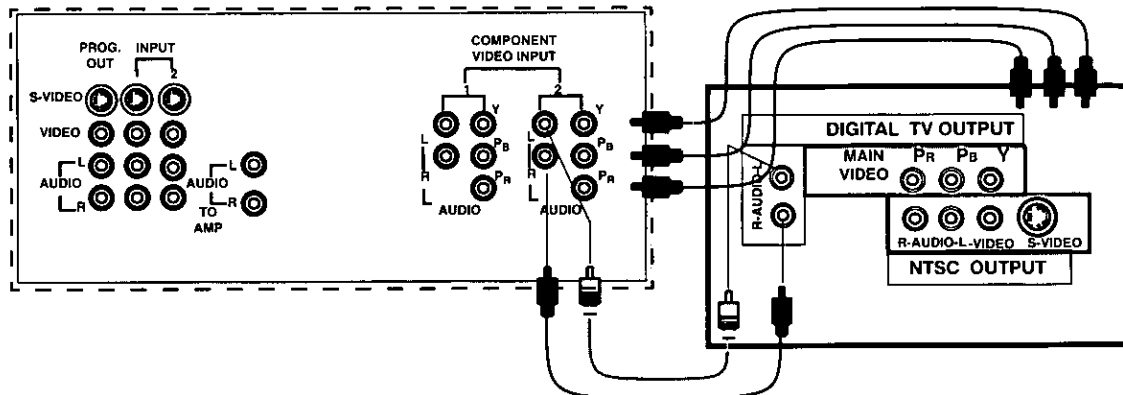

**Note:** There are two sets of component video inputs. Each has three video inputs, Y, P<sub>B</sub> and P<sub>R</sub>. Separate component color inputs provide luminance and color separation. Use component audio input 1 or 2 L (left) and R (right) for connecting to audio output of Panasonic DTV-STB.

## **Digital Television**

Digital Television (DTV) broadcasts are available in at least 10 major U.S. markets. Broadcasts will be in both high definition (HDTV) and standard definition (SDTV). The HDTV signal formats are 1080i (interlaced scan) and 720p (progressive scan). SDTV signal formats are 480i and 480p.

### **HDTV-Compatible (1080i/720p)**

HDTV-compatible TV models process and display the high definition output from a DTV Set-top Box (STB) at 1080i (interlaced) or 720p (progressive) lines. When 1080i or 720p HDTV is available in your viewing area, your TV will be compatible when using a Panasonic DTV-STB, model TU-DST50 or TU-DST51.

### **SDTV-Compatible (480p/480i)**

SDTV-compatible TV models process and display the standard definition output with the use of a Panasonic DTV-STB at 480 lines, interlaced or progressive scan. When DTV programming is available, you can view it in the standard format, 4:3 aspect ratio.

### **DTV Compatibility of PT-56WXF95**

This TV is capable of displaying both 1080i and 720p HDTV signals as well as the 480p/480i SDTV signals using a Panasonic DTV-STB, model TU-DST50 or TU-DST51. In order to view DTV programming, the STB must be connected to the TV by component video (Y, P<sub>B</sub>, P<sub>R</sub>) and audio inputs. A DTV signal must be available in your area and the DTV-STB must be tuned to the proper channel.

### **Color Matrix Adjustment**

When viewing DTV programming from a DTV-STB, this TV automatically adjusts the color parameters for 1080i, 720p and 480p transmissions. However, when viewing a nonstandard DTV signal format, you can change the color parameters manually in the Roller Guide PICTURE Menu for best picture quality.

### **Progressive Scan**

Progressive scan de-interlaces the incoming 480i signal and progressively scans the image. This allows you to sit very close to the TV and not see the thin black horizontal scan lines (venetian blind effect) associated with an interlaced picture.



## ***Frequently Asked Questions About Digital TV***

### **What is digital TV (DTV)?**

In April, 1997, the FCC (Federal Communications Commission) announced that, by 2006, all television broadcasting will be digital. Digital TV broadcasting delivers crystal-clear pictures, approaching the quality of 35mm movies and CD (compact disc) sound. Digital broadcasts include both High Definition Television (HDTV) and Standard Definition Television (SDTV). Broadcasters may choose their own broadcast formats.

#### **HDTV (High Definition Television)**

One form of digital broadcasting is HDTV, which provides the highest resolution picture. Besides incredible picture, the sound will be available in the 5.1 channel surround sound.

#### **SDTV (Standard Definition Television)**

Another form of digital broadcasting is SDTV, which provides lower resolution, but still presents a very sharp, clear picture. Lower resolution allows broadcasters to transmit more than one program per channel.

### **When will TV stations start broadcasting digital signals?**

Television stations are required to continue broadcasting regular TV signals along side the digital signals until 2006. Cable TV and satellite TV are not affected by this FCC ruling.

All stations are required to become digital by 2006. This will be an evolutionary process. According to the FCC, digital broadcasting must be available in the top ten markets, covering 30% of households by May 1999. By the end of 1999, digital broadcasting must be available in the top 30 markets, covering 50% of households.

### **Will I be able to adapt my current TV to receive digital broadcasts?**

Manufacturers will offer a digital TV set-top box (DTV-STB) which will allow current televisions to display digitally broadcast programs. The picture and sound quality will be about the same as small dish digital satellite systems today.

Conventional televisions (non-digital televisions) will not be able to display the HDTV resolution quality or sound.

### **What digital formats will broadcasters use?**

















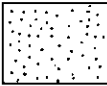

There are presently four DTV formats: 1080i (interlaced), 720p (progressive), 480i and 480p. The higher numbers indicate a higher resolution picture.

In an interlaced picture, the odd numbered lines (picture information) are scanned first creating field 1 and then the even numbered lines are scanned, creating field 2. The two fields are then interlaced to provide the entire image (one frame). This process happens in 1/30<sup>th</sup> of a second and is invisible to the human eye. In progressive scanning, all lines in the entire frame are scanned sequentially in 1/60<sup>th</sup> of a second.

Broadcasters may choose to transmit different levels of resolution throughout the day, broadcasting day programs in SDTV and night sports and movies in HDTV.

**Troubleshooting Chart**

Before calling for service, determine the symptoms and follow suggested solutions.

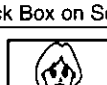
<b>AUDIO</b>	<b>VIDEO</b>	<b>Solutions</b>
 Noisy Audio	 Snowy Video	Adjust Antenna Location and Connection
 Noisy Audio	 Multiple Image	Adjust Antenna Location and Connection Check Antenna Lead-in Wire
 Noisy Audio	 Interference	Move TV from Electrical Appliances, Lights, Vehicles, and Medical Equipment
 No Audio	 Normal Video	Increase Volume Check Mute Check TV SPEAKERS on/off Change Channel
 Noisy Audio	 No Video	Set TV or Cable Mode Properly Check Antenna Cables
 No Audio	 No Video / No Split Screen	Check Power Cord is Plugged into Active Outlet Adjust Brightness and Audio Controls Change Channel Check Cable Connections Program the Remote Control Again Check Second Video Source Operation
 Normal Audio	 No Color	Adjust Color Settings Change Channel
 Wrong Audio	 Normal Video	Check Audio Is Set To Stereo Or Mono, Not SAP
 Normal Audio	 Black Box on Screen	Change CC (Closed Captioning) from Text Mode
 Normal Audio	 Normal Video	Replace Remote Control Batteries
Intermittent Remote Control Operation		